

# Product Description and Technical Data

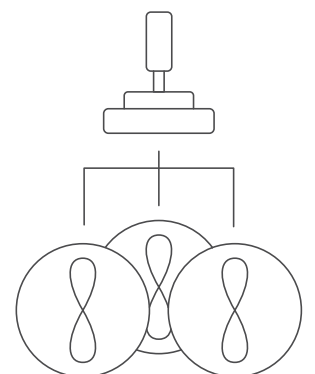

# argoPositionPilot

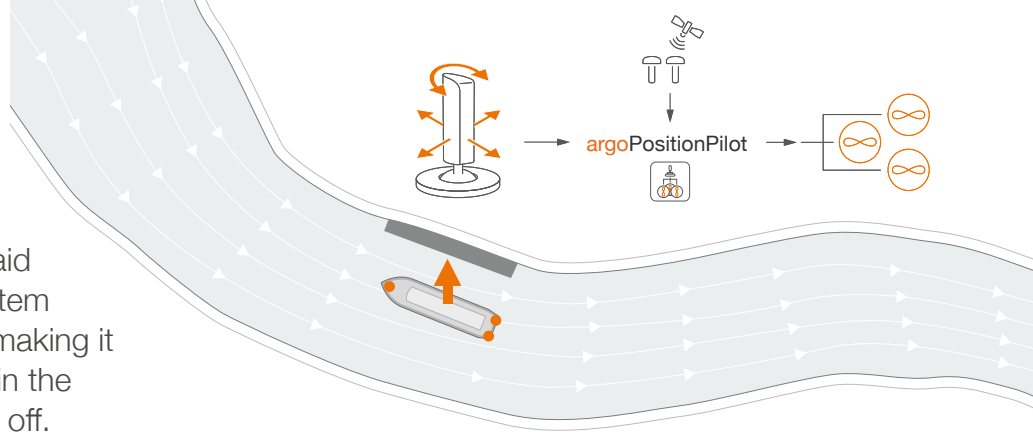

argoPositionPilot is a maneuvering aid for inland waterway vessels. The system enables intuitive control of the ship, making it easier to maneuver in front of locks, in the harbor and when mooring or casting off.

argoPositionPilot regulates the longitudinal, transverse, and rate-of-turn speed of the vessel according to the skipper's input using the joystick. Speed and rotation are controlled by the system. This means that the ship can be controlled with just one joystick instead of several levers.

## Features

- Operated via a 3-way joystick
- Mode switching via control panel
- Individual connection to azimuth drives from manufacturers Schottel, Veth, Verhaar Omega, Voith-Schneider and many more possible
- In addition, several external control stations can be connected

## Benefits and possible applications

- Safe operation thanks to intuitive joystick control
- Only **one** joystick to control the speed and direction of the ship
- Simplifies complex maneuvers, e.g. when navigating locks and in port
- Display and operation with argoControlPanel *flex* possible on all PCs
- Perfect integration of argoTrackPilot

## Prerequisites

### (Use of existing equipment)

- GNSS compass and ROT indicator
- ECDIS chart display
- Azimuth drives with compatible interface



argoPositionPilot is currently only available for ships with azimuth drives.

## Scope of delivery argoPositionPilot

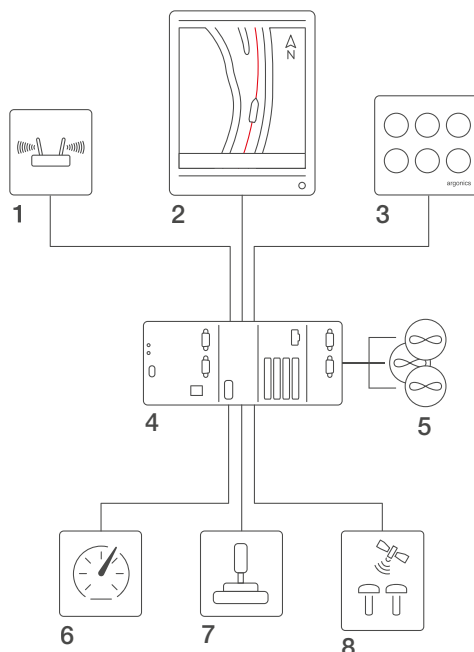
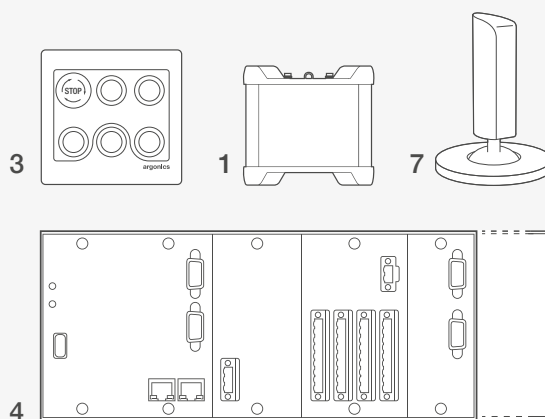

## System overview

- 1 LTE modem
- 2 ECDIS, e.g., argoRadarPilot with argoControlPanel *flex*
- 3 Control panel argoPositionPilot
- 4 Control system argoPositionPilot MC206, certified by DNV, BV
- 5 Connection of azimuth drives
- 6 ROT indicator
- 7 Joystick
- 8 GNSS compass

# Technical Data

## Joystick

IP rating	IP 56
Dimensions	width: 100 mm, height: 204 mm, depth: 100 mm
Weight	approx. 0.8 kg
Operating temperature	-25 °C ... 70 °C
Relative humidity	max. 95 % (at 55 °C)
Conformity	ENV-3, Lloyds / Class B, DNV-GL

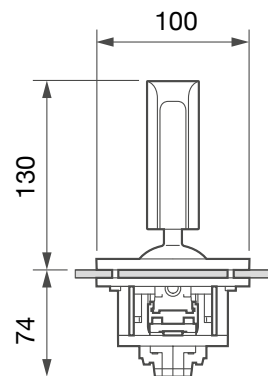

## Control panel

IP rating	IP 65
Dimensions (front plate)	width: 130 mm, height: 130 mm
Dimensions (mounting)	width: 120 mm, height: 120 mm, depth: 110 mm
Weight	approx. 700 g
Ambient temperature	-25 °C ... 60 °C
Storage temperature	-40 °C ... 85 °C
Relative humidity	5 % ... 95 %

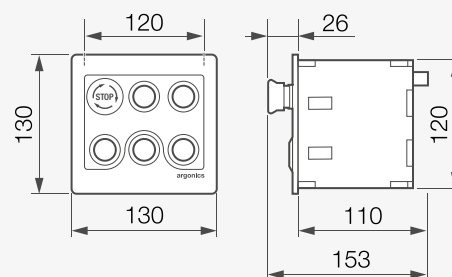

## Control system / PLC

Supply voltage	18VDC ... 32VDC
Supply current	1.5A
Dimensions*	width: 280 mm ... 400 mm height: 120 mm, depth: 60 mm
Weight	1.75 ... 2.45 kg
Ambient temperature	-25 °C ... 60 °C
Storage temperature	-40 °C ... 85 °C
Relative humidity	5 % ... 95 %

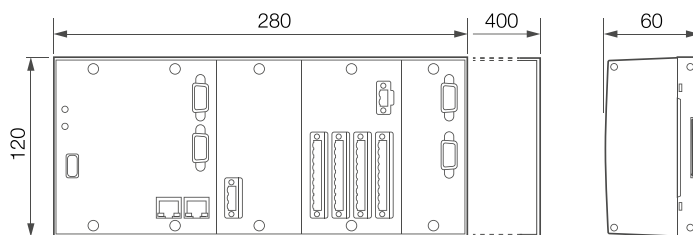

Incl. terminal block for power supply (not pictured)

\*Dimensions dependent on the number and interface of the azimuth drives and number of external control stations

## Modem\*

IP rating	IP 30
Supply voltage	9VDC ... 30VDC
Dimensions	width: 109.6 mm, height: 100 mm, depth: 50.1 mm
Weight	280 g
Ambient temperature	-40 °C ... 75 °C
Relative humidity	10 % ... 90 %
Conformity	ES-TRIN 10.20

\*Incl. antennas (not displayed)

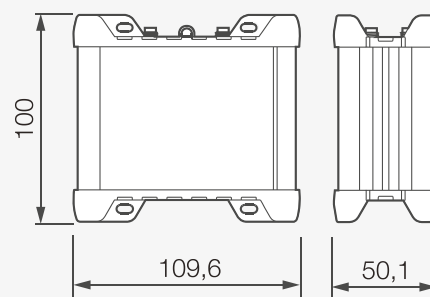

argonics.de

**argonics**  
an Alpatron Marine company

argonics GmbH  
Heßbrühlstraße 21D  
70565 Stuttgart  
Germany

info@argonics.de  
+49 711 / 25253720